



Series

DCC-DFE-DFN-DFF

Air/oil separation FAI FILTRI

INTRODUCTION TO AIR/OIL SEPARATION

FAI FILTRI high quality standards has allowed the production of air/oil separator for air purification into rotary/vane compressors. This has to be considered as a fundamental premise for systems meant to operate in the food processing, electronic, pharmaceutical, textile fields, etc.

These products are manufactured in two distinct ranges: a compact spin-on series and a basket-shaped one for assembly into pressure vessels.

FAI FILTRI air/oil separators peculiarity lies into their retaining most of the aerosol oil contained into the compressed air flow, generated by entrainment during screw or vanes lubrication.

The compressed air, contaminated by microscopic oil drops and solid particles, flows through the first layer of reinforced borosilicate micro-fibers, causing the aerosol microscopic droplets with a diameter lower than 1 micron, to coalesce into larger drops. These are then caught and drained by a second layer of synthetic porous material and end up, due to the gravity, on the dry side of separator.

TECHNICAL DATA

MATERIALS

Galvanized sheet steel

High quality multilayer borosilicate glass-fiber separator medium

PRESSURE DROP

With nominal flow rates and pressure at 7 bar: 0,2 bar (clean filter)

SERVICE LIFE

Filter shall be replaced when a differential pressure drop (DP) of 1-1,2 bar is reached. Market researches have shown that an average working life of several thousand hours can be achieved under normal working conditions. An increased pressure drop and, as a consequence, a reduced service life may opened on the quality.

WORKING PRESSURE

Max working pressure: 20 bar

FILTER ELEMENT COLLAPSING PRESSURE

DP \geq 5 bar

WORKING TEMPERATURE

From -25°C up to $+110^{\circ}\text{C}$

FLOW RATE

See dimensional table

PRESSURE DROP AND RESIDUAL OIL

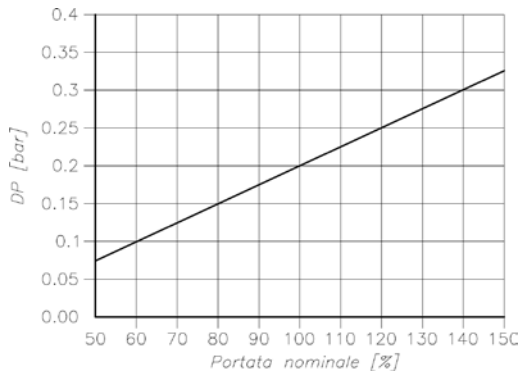

Pressure drop on FAI FILTRI air/oil separator at working pressure. Diffusion depends upon pre-separation within the compressor

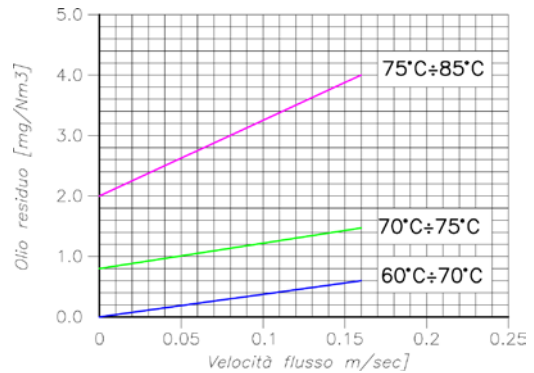

Oil carry over related to flow velocity and temperature

PRINCIPLE OF COALESCENCE

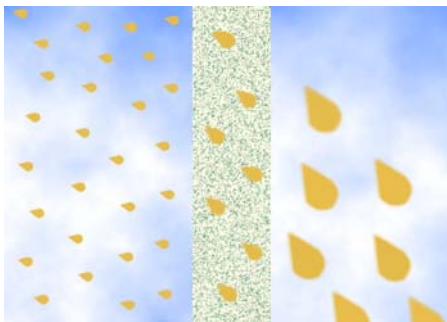

The compressed air, contaminated by a microscopic oil droplets and solid particles, flows through the first layer of reinforced borosilicate micro-fibers, causing the aerosol microscopic droplets with a diameter lower than 1 micron, to coalesce into larger drops. These are then caught and drained by a second layer of synthetic porous material and end up, due to the gravity, on the dry side of separator

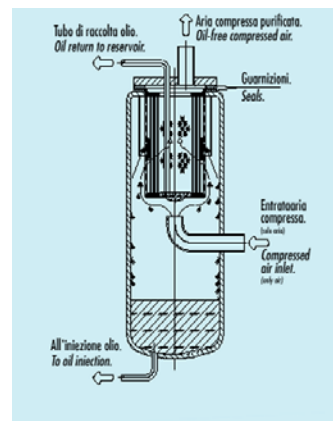

Assembly air/oil separator in a pressure vessel

DIMENSIONAL INFORMATION

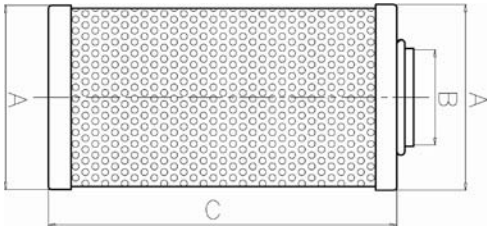

Model "A"

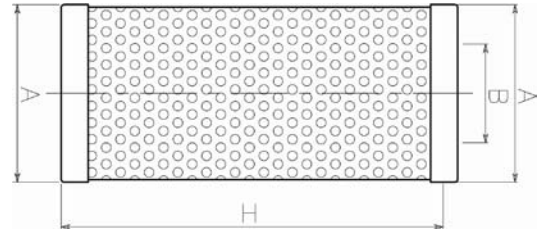

Model "B"

DCC series							DCC series for vacuum pump						
Type	ØA	ØB	ØC	H	Flow rate m³/min	Model	Type	ØA	ØB	ØC	H	Flow rate m³/min	Model
DCC051092.00	50	30.5	5.2	92		B	DCC030064.00	30	10	5.2	64		B
DCC052232.00	53	30	-	237		A	DCC034064.00	35	9.5	-	64		A
DCC080096.00	80	40	40	96		B	DCC039092.00	40	13	5.2	92		B
DCC080127.01	80	40	-	127		B	DCC051092.00	50	30.5	5.2	92		B
DCC080255.00	82.5	20	-	298		A	DCC052128.00	52	29	-	120		A
DCC092240.00	90	53	53	240		B	DCC052240.00	52	29	-	240		A
DCC092490.00	90	53	53	490		B	DCC052068.00	55	25.5	25.5	71		B
DCC100156.00	100	50	-	156	1.5	B	DCC055124.00	55	25	25	124	0.4	B
DCC100250.00	100	70	70	250	2.1	B	DCC055195.00	54	20	-	220	2.1	A
DCC100350.00	100	50	-	350		B	DCC056132.00	56	25	25	132	0.7	B
DCC114165.00	114	66	66	165	1.5	B	DCC056158.00	56	24	5.5	152		B
DCC114245.01	117	86	14	245		B	DCC065100.00	65	44		100		B
DCC114340.00	114	66	66	340	3.4	B	DCC066228.00	66	40	5.5	228		B
DCC114500.00	114	66	66	500	5	B	DCC066397.00	66	40.5	5.5	397		B
DCC135130.2X	132	76	8.5	130		B	DCC068132.00	68	40	40	132	0.9	B
DCC135200.00	133	66	66	200	2.6	B	DCC070240.00	70	40	40	240	1.5	B
DCC135240.00	133	66	66	240	3.1	B	DCC070240.01	70	26	26	240		B
DCC170200.0W	170	120	120	200	3.3	B	DCC072074.00	72	33		250	1.7	B
DCC170254.0W	170	120	14	254	4.2	B	DCC072100.00	72	33	33	100		B
DCC170340.01	170	120	120	340		B	DCC072132.00	72	35		140		A
DCC170420.0W	170	120	120	420	6.9	B	DCC072132.01	72	35		140		A
DCC220420.00	220	166	166	420		B	DCC072210.00	72	35		210		A
DCC220600.01	220	166	166	600		B	DCC072250.00	72	35		250	1.6	A
							DCC072250.01	72	35		250	1.7	A
							DCC072375.00	72	35		375	208	A
							DCC072375.01	72	35		375	208	A
							DCC072500.00	72	35		500	3.6	A
							DCC072500.01	72	35		500	3.6	A
							DCC074250.00	74	35	35	250		B
							DCC070117.00	80	45	45	117	0.9	B
							DCC080422.00	80	48		420		B
							DCC100245.00	100	68		250	2.1	B
							DCC100285.00	100	68		285		B
							DCC106218.00	106	72	72	218	1.8	B
							DCC106283.00	106	72	72	283	4.5	B
							DCC123460.00	123	88	88	460		B
							DCC123630.00	123	88	88	630		B

DFF series

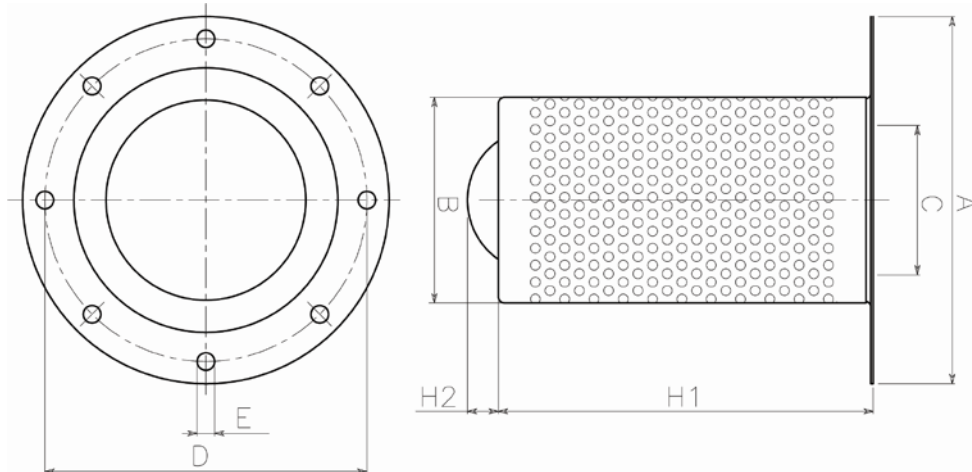

Type	ØA	ØB	ØC	H1	H2	ØD	ØE	Holes Nr.	Flow rate m³/min
DFF100285.00	140	100	57	285		121	11	5	
DFF100485.00	140	100	57	485		121	11	8	
DFF114165.01	160	14	66	165		133.5	12	8	1.6
DFF114280.00	160	114	360	280		135	12	8	
DFF135160.00	205	133	88	160	12	180	13	8	1.8
DFF135240.00	240	133	88	202	11	212	12	8	2.3
DFF150235.0U	355	150	83	235		318	17	8	
DFF150465.0U	350	150	83	465			11	1	
DFF160090.00	216	160	90	90	12	192	13	8	
DFF170160.01	218	170	110	160		190	12	6	2.3
DFF170230.03	220	170	122	230	12	190	12	6	3.5
DFF170305.04	300	170	122	307	12	272	16.5	12	4.5
DFF170410.00	280	170	122	410		241	18	8	6.3
DFF170485.00	300	170	122	484	12	266	17	12	7.7
DFF200220.0W	298	200	140	220		268	17	8	3.6
DFF200460.0W	320	200	140	460		286	20	12	8
DFF220180.01	273	220	158	180		250	16.5	16	3.3
DFF220230.02	273	220	158	230		250	16.5	16	4.4
DFF220305.02	273	220	158	305		250	16.5	16	5.9
DFF200350.02	300	220	158	345		272	14	12	6.8
DFF200435.00	378	220	165	432	14	350	18	16	17.2
DFF220590.00	350	220	179	590		233	11	1	
DFF262350.00	400	263	165	348	12	354	22	16	6.8
DFF262545.00	400	263	165	545	12	354	22	16	
DFF275180.00	370	275	215	180	12	336	18	10	4.8
DFF275305.01	327	275	219	305	13	296	7	16	8.1
DFF275350.03	404	275	215	348	13	362	18	10	9.2
DFF275500.00	400	275	217	500		354	22	16	10
DFF275820.00	400	275	217	820		354	22	16	21.4
DFF300600.00	400	300	243	600		360	13	13	
DFF350445.00	500	350	264	445		462	23	23	
DFF375380.0U	458	375	298	380		419	20	20	
DFF375760.0W	613	375	314	760		584	18	18	
DFF475920.01	735	475	397	900	12	685	30	30	
DFF530930.0U	675	530	467	930		328	22	22	

DFN series

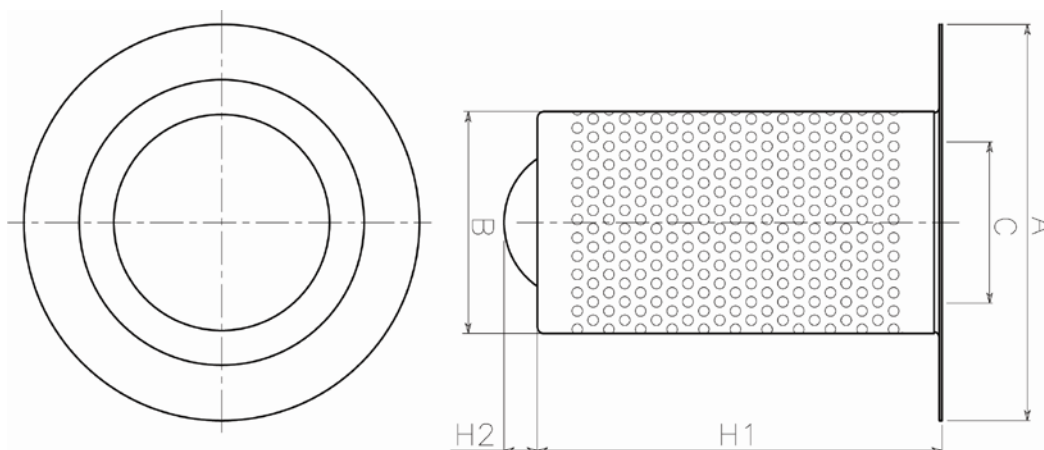

Type	ØA	ØB	ØC	H1	H2	Flow rate m³/min	Type	ØA	ØB	ØC	H1	H2	Flow rate m³/min
DFN073220.2X	111	73	28.5	220	15		DFN275450.00	325	275	220	450	13	12
DFN110225.00	155	110	60.5	233			DFN275500.2X	325	275	210	500		
DFN125140.00	164	125	78	140			DFN275600.00	365	275	210	600		
DFN127270.2X	164	125	120	270	12		DFN275750.00	325	275	220	750	13	20
DFN135140.00	165	135	88	140	12		DFN275980.2X	370	275	200	980		
DFN135200.00	170	135	76	200		4.5	DFN300305.00	355	300	220	305		16
DFN135200.01	170	135	88	200	12	2	DFN300350.00	355	300	220	350		
DFN135305.00	170	135	88	300	12	3.5	DFN300400.00	355	300	220	400		22
DFN135305.01	170	135	79	305			DFN300500.00	355	300	220	500		28
DFN150200.2X	215	150	100	200			DFN300500.0W	355	300	243	500	11	14
DFN150250.0J	220	145	68	250			DFN300600.00	355	300	243	600	11	17
DFN150420.0U	197	150	92	420			DFN300600.03	355	300	220	600		33.5
DFN170160.01	192	170	122	160	12		DFN300660.2X	355	300	243	650	11	19
DFN170200.00	248	170	122	220	12		DFN300700.00	355	300	220	700		39
DFN170230.00	200	170	122	115	12	3.5	DFN300820.00	355	300	243	820	11	24
DFN170230.07	200	170	108	230		6.5	DFN3001000.00	355	300	243	10000	12	29
DFN170305.00	200	170	122	306	12	4.5	DFN375360.0U	420	375	300	365		
DFN170305.06	200	170	108	305		9	DFN375590.2X	460	375	310	590		
DFN170400.00	200	170	108	400			DFN3745720.0U	430	375	317	720		
DFN170435.00	200	170	122	433	12	6.5	DFN3751070.2X	470	375	279	1070		
DFN170485.00	200	170	122	485	12		DFN400520.2X	440	400	314	520		
DFN220200.00	273	220	165	196	14		DFN4006200.2X	440	400	314	620		
DFN220230.00	273	220	158	228	70		DFN475455.2X	540	475	397	455		
DFN220253.2X	286	220	158	250			DFN475565.1U	605	475	385	565		
DFN220305.00	273	220	158	305			DFN475825.00	675	475	397	825		
DFN220360.2X	336	220	158	345			DFN475920.01	735	475	397	900	12	42
DFN220435.2X	273	220	165	430	14	9	DFN530930.0U	583	530	467	930		
DFN220540.2X	305	220	140	540									
DFN220600.00	273	220	165	600	14	12							
DFN275250.00	325	275	210	250									
DFN275305.00	325	275	220	305	13	8							
DFN275400.00	325	275	210	400		20							

DFE series

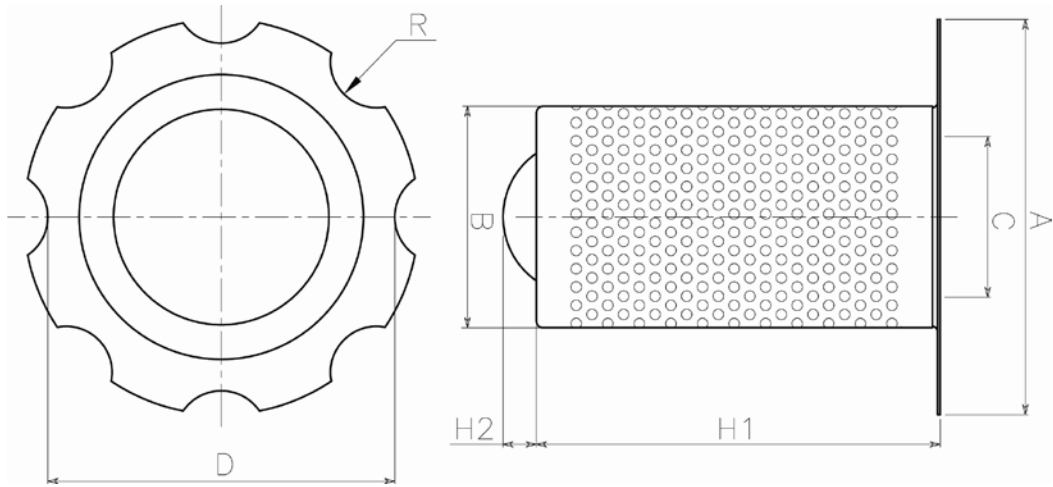

Type	ØA	ØB	ØC	H1	H2	ØD	ØE	Holes Nr.	Flow rate m ³ /min
DFE073133.00	124	73	35	134	6.5	112	6	6	
DFE135230.0W	170	133	76	231		156	10.5	8	
DFE170230.00	200	170	122	230	12	186	10.5	8	
DFE170435.00	200	170	122	435	12	186	10.5	8	
DFE220240.0W	271	220	158	240		242	11	8	
DFE300500.0W	400	342	243	580		380	9	10	
Type	ØA	ØB	ØC	H1	H2	ØD	ØE	Holes Nr.	Flow rate m ³ /min
DFE073133.00	124	73	35	134	6.5	112	6	6	
DFE135230.0W	170	133	76	231		156	10.5	8	
DFE170230.00	200	170	122	230	12	186	10.5	8	
DFE170435.00	200	170	122	435	12	186	10.5	8	
DFE220240.0W	271	220	158	240		242	11	8	
DFE300500.0W	400	342	243	580		380	9	10	